

1260 VXI SWITCHING CARD

1260-64M MODULAR MICROWAVE SWITCH MODULE

PUBLICATION NO. 980673-062

RACAL INSTRUMENTS

Racal Instruments, Inc.

4 Goodyear St., Irvine, CA 92618-2002
Tel: (800) RACAL-ATE, (800) 722-2528, (949) 859-8999; FAX: (949) 859-7139

Racal Instruments, Ltd.

480 Bath Road, Slough, Berkshire, SL1 6BE, United Kingdom
Tel: +44 (0) 1628 604455; FAX: +44 (0) 1628 662017

Racal Systems Electronique S.A.

18 Avenue Dutartre, 78150 LeChesnay, France
Tel: +33 (1) 3923 2222; FAX: +33 (1) 3923 2225

Racal Systems Elettronica s.r.l.

Strada 2-Palazzo C4, 20090 Milanofiori Assago, Milan, Italy
Tel: +39 (0)2 5750 1796; FAX +39 (0)2 5750 1828

Racal Elektronik System GmbH.

Technologiepark Bergisch Gladbach, Friedrich-Ebert-Strasse, D-51429 Bergisch Gladbach, Germany
Tel.: +49 2204 8442 00; FAX: +49 2204 8442 19

Racal Instruments, Ltd.

Unit 5, 25F., Mega Trade Center, No 1, Mei Wan Road, Tsuen Wan, Hong Kong, PRC
Tel: +852 2405 5500, FAX: +852 2416 4335

<http://www.racalstruments.com>



PUBLICATION DATE: Oct. 01, 2002

Copyright 2002 by Racal Instruments, Inc. Printed in the United States of America. All rights reserved.
This book or parts thereof may not be reproduced in any form without written permission of the publisher.

THANK YOU FOR PURCHASING THIS RACAL INSTRUMENTS PRODUCT.

For this product, or any other Racal Instruments product that incorporates software drivers, you may access our web site to verify and/or download the latest driver versions. The web address for driver downloads is:

<http://www.racalstruments.com/downloads>

You will be asked to register one time only to gain access to the driver and product manual downloads sections. At registration a cookie will be placed on your computer if you choose to accept it. This is done to facilitate your use of these sections on future visits. You may refuse to accept the cookie and still have complete access to the software driver database but will have to re-register every time you visit. This cookie is for ease of use only and no information is gathered for, sold, or reported to, any third party organization.

If you have any questions about software driver downloads or our privacy policy, please contact us at

info@racalstruments.com.

WARRANTY STATEMENT

All Racal Instruments, Inc. products are designed and manufactured to exacting standards and in full conformance to Racal's ISO 9001 procedures.

This warranty does not apply to defects resulting from any modification(s) of any product or part without Racal's express written consent, or misuse of any product or part. The warranty also does not apply to fuses, software, non-rechargeable batteries, damage from battery leakage, or problems arising from normal wear, such as mechanical relay life, or failure to follow instructions.

This warranty is in lieu of all other warranties, expressed or implied, including any implied warranty of merchantability or fitness for a particular use. The remedies provided herein are buyer's sole and exclusive remedies.

For the specific terms of your standard warranty, or optional extended warranty or service agreement, contact your Racal customer service advisor. Please have the following information available to facilitate service.

1. Product serial number
2. Product model number
3. Your company and contact information

You may contact your customer service advisor by:

E-Mail:	Helpdesk@racalstruments.com	
Telephone:	+1 800 722 3262	(USA)
	+44(0) 8706 080134	(UK)
	+852 2405 5500	(Hong Kong)
Fax:	+1 949 859 7309	(USA)
	+44(0) 1628 662017	(UK)
	+852 2416 4335	(Hong Kong)

RETURN of PRODUCT

Authorization is required from Racal Instruments before you send us your product for service or calibration. Call your nearest Racal Instruments support facility. A list is located on the last page of this manual. If you are unsure where to call, contact Racal Instruments, Inc. Customer Support Department in Irvine, California, USA at 1-800-722-3262 or 1-949-859-8999 or via fax at 1-949-859-7139. We can be reached at: helpdesk@racalstruments.com.

PROPRIETARY NOTICE

This document and the technical data herein disclosed, are proprietary to Racal Instruments, and shall not, without express written permission of Racal Instruments, be used, in whole or in part to solicit quotations from a competitive source or used for manufacture by anyone other than Racal Instruments. The information herein has been developed at private expense, and may only be used for operation and maintenance reference purposes or for purposes of engineering evaluation and incorporation into technical specifications and other documents which specify procurement of products from Racal Instruments.

DISCLAIMER

Buyer acknowledges and agrees that it is responsible for the operation of the goods purchased and should ensure that they are used properly and in accordance with this handbook and any other instructions provided by Seller. RII products are not specifically designed, manufactured or intended to be used as parts, assemblies or components in planning, construction, maintenance or operation of a nuclear facility, or in life support or safety critical applications in which the failure of the RII product could create a situation where personal injury or death could occur. Should Buyer purchase RII product for such unintended application, Buyer shall indemnify and hold RII, its officers, employees, subsidiaries, affiliates and distributors harmless against all claims arising out of a claim for personal injury or death associated with such unintended use.

FOR YOUR SAFETY

Before undertaking any troubleshooting, maintenance or exploratory procedure, read carefully the **WARNINGS** and **CAUTION** notices.

This equipment contains voltage hazardous to human life and safety, and is capable of inflicting personal injury.

If this instrument is to be powered from the AC line (mains) through an autotransformer, ensure the common connector is connected to the neutral (earth pole) of the power supply.

Before operating the unit, ensure the conductor (green wire) is connected to the ground (earth) conductor of the power outlet. Do not use a two-conductor extension cord or a three-prong/two-prong adapter. This will defeat the protective feature of the third conductor in the power cord.

Maintenance and calibration procedures sometimes call for operation of the unit with power applied and protective covers removed. Read the procedures and heed warnings to avoid "live" circuit points.

Before operating this instrument:

1. Ensure the instrument is configured to operate on the voltage at the power source. See Installation Section.
2. Ensure the proper fuse is in place for the power source to operate.
3. Ensure all other devices connected to or in proximity to this instrument are properly grounded or connected to the protective third-wire earth ground.

If the instrument:

- fails to operate satisfactorily
- shows visible damage
- has been stored under unfavorable conditions
- has sustained stress

Do not operate until performance is checked by qualified personnel.

Racal Instruments

EC Declaration of Conformity

We

Racal Instruments Inc.
4 Goodyear Street
Irvine, CA 92718

declare under sole responsibility that the

1260-64M Modular Microwave Switch Module, P/N 407816

conforms to the following Product Specifications:

Safety: EN61010-1:1993+A2:1995

EMC: EN61326:1997+A1:1998

Supplementary Information:

The above specifications are met when the product is installed in a Racal Instruments certified mainframe with faceplates installed over all unused slots, as applicable

The product herewith complies with the requirements of the Low Voltage Directive 73/23/EEC and the EMC Directive 89/336/EEC (modified by 93/68/EEC).

Irvine, CA, July 29, 2002

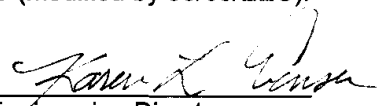
Engineering Director

This page was left intentionally blank.

Table of Contents

Chapter 1

MODULE SPECIFICATIONS.....	1-1
General	1-1
Specifications	1-2
1x16 Switch Arrays Specifications.....	1-2
General	1-3
Ordering Information	1-5

Chapter 2

INSTALLATION INSTRUCTIONS	2-1
Unpacking and Inspection	2-1
Reshipment Instructions.....	2-1
Option 01T Installation	2-1
Lockout Keys	2-2
Module Installation	2-2
Relay Bank Configuration.....	2-2
Microwave Plug-In Installation.....	2-3

Chapter 3

MODULE OPERATION	3-1
Operating Modes.....	3-1
Operating In Message-Based Mode	3-3
Operating In Register-Based Mode	3-8

Chapter 4

CONNECTOR PIN CONFIGURATION.....	4-1
RF Relays	4-1
Relay Banks.....	4-1

Chapter 5

THEORY OF OPERATION5-1
 PCB Assemblies5-1

Chapter 6

PRODUCT SUPPORT6-1
 Product Support.....6-1
 Reshipment Instructions6-1
 Support Offices6-2
 Repair and Calibration Request Form.....6-3

List of Figures

Figure 1-1, 1260-64M	1-1
Figure 4-1, 1260-64M Front Panel.....	4-2
Figure 4-2, Relay Bank Pin Configuration (J1).....	4-3
Figure 4-3, Internal Supply Sink Driver Example.....	4-4
Figure 4-4, External Supply Sink Driver Example	4-4
Figure 4-5, Internal Supply Source Driver Example	4-5
Figure 4-6, External Supply Source Driver Example	4-5

List of Tables

Table 2-1, Plug-In Connections	2-4
Table 3-1, Control Register Memory Map	3-9
Table 3-2, Plug-In Module ID Codes.....	3-10
Table 4-1, 1260-64M Pin Assignments	4-3

This page was left intentionally blank.

Chapter 1

MODULE SPECIFICATION

General

The 1260-64M consists of a universal 2-slot VXI microwave relay carrier and up to four modular microwave switch plug-ins. All microwave switches are front pluggable to facilitate ease of replacement and repair. The 1260-64M also includes 32 SPST relays configured as two 1 X 16 banks intended to drive external RF relays, although other applications are possible.



Figure 1-1, 1260-64M

Standard RF Specifications

Quantity of RF Switches	4 plug-in locations, up to 3 - 1 X 2 per plug-in (configuration dependent)
User Connectors: SMA, K-Type – Caution - Mating Connector engagement should not exceed 9-in. lbs. torque maximum.	
Recommended Torque Wrench:	Wiltron Model 01-201, 8in. lbs.
Frequency Range	DC to 40GHz (switch dependent)
RF Impedance	50Ω, nominal
Insertion Loss, dB Max	0.2 DC –3GHz 0.3 3GHz-8GHz 0.4 8GHz – 12GHz 0.5 12GHz-18GHz 18GHz-40GHz (switch dependent)
Isolation, dB Min	80 DC-3GHz 70 3GHz-8GHz 60 8GHz – 18GHz 18GHz-40GHz (switch dependent)
VSWR, Max	1.2:1 DC-3GHz 1.3:1 3GHz-8GHz 1.4:1 8GHz-12GHz 1.5:1 12GHz-18GHz 18GHz-40GHz (switch dependent)
Switching Sequence	Break-before-make
Minimum Option 01T Hardware Revision	405108 Rev. E, or later
Minimum Option 01T Firmware Revision	231559-001,Rev. G or later

1x16 Switch Arrays Specifications

User Connector	50-Pin Connector. Body Part #601855-050, Solder Type Pins #601857.
Number of Banks	2
Number of Switches per Bank	16, 1-wire

Relay Driver Configurations (User Configurable)	Source Driver, External Supply Source Driver, VXI +5V Supply Source Driver, VXI +12V Supply Source Driver, VXI +24V Supply Sink Driver, External Supply Sink Driver, VXI +5V Supply Sink Driver, VXI +12V Supply Sink Driver, VXI +24V Supply
--	--

(External flyback-suppression diodes are required when switching inductive loads.)

Maximum Total VXI Current Available to Drive External Loads

+24V	1A (May be further limited by mainframe capability).
+12V	1A (May be further limited by mainframe capability)
+5V	6A (May be further limited by mainframe capability)

Maximum Current per Bank 4A (Internal or External Supply)

Maximum Current per Switch .5Amp

Maximum Switchable Voltage 30V, DC Only

Maximum Switchable Power Per Channel 30W, 62.5 VA (Resistive Load)

Path Resistance:
Worst Case <1.8Ω (Initial)
End of Life <3.5Ω

Operating Mode Normally Open

General

Power Requirements (Ipm)

+5V	0.6A (1.6A with Option 01T installed + 0.03A per energized relay [1 X 16 bank] if any)
+12V	320mA per RF relay (energized) plus current drawn by external loads on 1x16 relay banks.

	+24V	Includes only current drawn by external loads from 1 X 16 bank (if any)
Cooling Requirements		
Airflow		1.0 L/S at 0.05 mm H ₂ O 2.0 L/S at 0.2m H ₂ O w/Option 01T
Weight		5.0lbs (2.27Kg) 5.25lbs (2.38Kg) with Option 01T

Ordering Information

Spares Ordering Information		
Model/Option	Description	Part Number
1260-64M	Carrier Assy	407816
VXI plug&play software	Installation Disk (Rev. S or later)	921534
Labview Driver	Installation Disk	921398-061
Option 01T	Message/Register Based Switch Controller (spare)	407531-001
Option 01T (installed)	Message/Register Based Switch Controller (installed)	Opt-405108-001
1264M Ship Kit	Ship Kit	407818
1260-64M	User Manual (included in Ship Kit)	980673-062
1260-64M Plug-in	3-1X2 @ 18GHz, terminated	407819-203
1260-64M Plug-in	1-1X6 @ 18GHz, terminated	407819-206
1260-64M Plug-in	1-1X2 @ 18GHz, latching & terminated	407819-302
1260-64M Plug-in	1-1X6 @ 18GHz, latching & terminated	407819-306
1260-64M Plug-in	1-1X2 @ 40GHz	407819-402
1260-64M Plug-in	1-1X6 @ 40GHz	407819-406
1260-64M Plug-in	2-1X16 Channel Driver	407819-032
1260-64M Plug-in	Blank Plate	457008

This page was left intentionally blank.

Chapter 2

INSTALLATION INSTRUCTIONS

Unpacking and Inspection

1. Before unpacking the switching module, check the exterior of the shipping carton for any signs of damage. All irregularities should be noted on the shipping bill.
2. Remove the instrument from its carton, preserving the factory packaging as much as possible.
3. Inspect the switching module for any defect or damage. Notify the carrier immediately if any damage is apparent.
4. Have a qualified person check the instrument for safety before use.

Reshipment Instructions

1. Use the original packing if it is necessary to return the switching module to Racal Instruments for calibration or servicing. The original shipping carton and the instrument's plastic foam will provide the necessary support for safe reshipment.
2. If the original packing is unavailable, wrap the switching module in plastic sheeting and use plastic spray foam to surround and protect the instrument.
3. Reship in either the original or a new, sturdy shipping carton.

Option 01T Installation

Installation of the Option 01T into the 1260-64M is described in the Installation section of the 1260-Series VXI Switching Cards Manual. Note that lockout keying for the double-wide 1260-64M module differs from that described in the 1260 manual section.

Lockout Keys

Lockout keying is not available for the 1260-64M. The system integrator must ensure that the module installed to the left and right of the 1260-64M has no conflict with the Local Bus implementation.

Module Installation

Installation of the 1260-64M Switching Module into a VXI mainframe, including the setting of DIP switches, is described in the Installation section of the 1260-Series VXI Switching Cards Manual. The ID byte DIP switches should be set as follows:

1260-64M 5=OFF 6=OFF (factory setting)

Relay Bank Configuration

If either of the two banks of DC relays are to be used, various internal jumpers must be installed. Examples of four possible configurations are shown in Figures 4-3 through 4-6. The card is shipped from the factory without any jumpers installed.

To access the jumpers, remove the right side cover from the module. The jumpers are located on the large PCB Assembly. There are two banks of relays. Each bank is configured independently, and the two configurations do not have to match. The banks are designated Bank A and Bank B.

The first consideration when configuring the relay banks is whether the bank is to act as a source driver or a sink driver. (A sink driver connects its output to ground to energize a load; a source connects its output to B+ to energize a load.) Eight push on jumpers are to be installed as shown below:

Bank A Source Driver:	W5.
Bank A Sink Driver:	W6.
Bank B Source Driver:	W11.
Bank B Sink Driver:	W12.

The next consideration is the source of power for the external loads on Bank A. If an external supply is to be used, the jumpers at locations W3 and W4 are to be removed. If the VXI +5V supply is to be used, eight jumpers are to be installed at location W3. (1-2, 3-4, 5-6, etc.) If the VXI +12V supply is to be used, three jumpers are to be installed at location W4 (1-2, 3-4, and 5-6) If the VXI +24V supply is to be used, the three jumpers are to be installed at location W4 (11-12, 13-14, 15-16).

The final consideration is the source of power for the external loads on Bank B. If an external supply is to be used, the

jumpers at locations W8 and W9 are to be removed. If the VXI +5V supply is to be used, eight jumpers are to be installed at location W8. (1-2, 3-4, 5-6, etc.) If the VXI +12V supply is to be used, three jumpers are to be installed at location W9 (1-2, 3-4, and 5-6) If the VXI +24V supply is to be used, the three jumpers are to be installed at location W9 (11-12, 13-14, 15-16).

The right cover can now be reinstalled on the module.

Microwave Plug-In Installation

Microwave plug-in modules typically are installed at the factory prior to shipment. Follow the instructions below to install a microwave plug-in into the carrier assembly (407816).

Each microwave plug-in consists of a connectorized relay and a unique cable assembly. Remove the right side cover (14 mounting screws) and feed the "P2" end of the cable assembly through the opening in the front panel of the carrier. Mate the "P2" connector (and "P3" if necessary) within the appropriate header as indicated in Table 2-1. Secure the plug-in to the carrier front panel with the hardware supplied. Replace the right side cover and secure.

Table 2-1, Plug-in Connections

Plug-In	P2 Connects To	P3 Connects To
1	J10	J11
2	J20	J21
3	J30	J31
4	J40	J41

Module Address Switches

Since 1260-Series switch modules do not communicate directly with the slot 0 controller, they do not use logical addresses. Instead, they use module addresses. Each 1260-Series module has its own unique module address from 1 to 12, inclusive. The Option-01T uses the module addresses to distinguish one switch module from others in the same group, in much the same manner as the slot 0 controller uses logical addresses for modules it communicates with.

- (1) Decide on a unique module address, from 1 to 12, inclusive, for each 1260-Series switch module.
- (2) Set the module address by using the DIP switch on the switch module (see Figure 1-3). If the module is a 1260-40, remove the module covers. For other modules, you may access the DIP switches through the openings in the bottom cover. Referring to Figure 1-3, set the switch module DIP switches to correspond with the desired module address. Each segment of the DIP switch represents a number, as shown in Figure 1-3. The module address equals the sum of the values of all switches that are set to the ON position. For example, to set the module address to 5, set switch segments 2 and 4 to ON, and set all others to OFF (switch 4 represents 1 and switch 2 represents 4, for a sum of 5). Switch 4 is the least significant bit.
 - (3) Repeat step (2) for each 1260-Series switch module. Make sure you assign a unique module address for each module.

Chapter 3

MODULE OPERATION

Operating Modes

The 1260-64M may be operated either in *message-based* mode or in *register-based* mode.

In the *message-based* mode, the 1260-01T switch controller interprets commands sent by the slot 0 controller, and determines the appropriate data to send to the control registers of the 1260-64M module.

A conceptual view of the message-based mode of operation is shown in **Figure 3-1**.

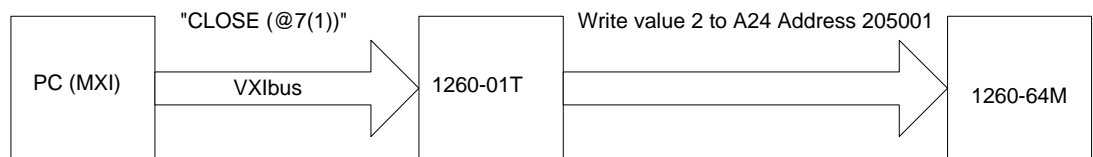

Figure 3-1, Message-Based Mode of Operation

In the *register-based* mode, the user writes directly to the control registers on the 1260-64M module. The 1260-01T command module does not monitor these operations, and does not keep track of the relay states on the 1260-64M module in this mode.

A conceptual view of the register-based mode is shown in **Figure 3-2** below.

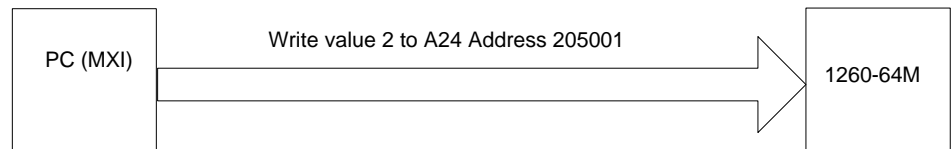

Figure 3-2, Register-Based Mode of Operation

Since the 1260-01T switch controller does not keep track of relay states during the register-based mode, it is advisable to use **either** the message-based or the register-based mode, and continue to use the same mode throughout the application program.

In general, the message-based mode of operation is easier to use with utility software such as the National Instruments VXI Interactive Control (VIC) program. The message-based mode allows the user to send ASCII text commands to the 1260-01T and to read replies from the 1260-01T. In addition, some features, such as the SCAN list, are available only in the message-based mode of operation.

The register-based mode provides faster control of relay channels. In this mode, relay operations are processed in less than 9 microseconds, not counting relay settling time or software overhead inherent in I/O libraries such as VISA. To determine the relay settling time, refer to Relay Settling Time in the Specifications section.

Consult the 1260-01T User's Manual for a comparison of the message-based and register-based modes of operation.

Operating In Message-Based Mode

Firmware Revision Required for Operating the 1260- 64M

In order to operate the 1260-64M using the message-based control, version 10.1 (or later) of the 1260-01T firmware must be installed in the 1260-01T controller.

You may send the “*IDN?” query to the 1260-01T to read the firmware revision installed in the 1260-01T. The reply to the “*IDN?” query will be in the format:

```
"Racal Instruments,1260A Option-01T, <SN>, <FW  
revision>"
```

The <SN> represents the serial number. The <FW revision> is the firmware revision that is installed in the 1260-01T. This should be at a revision of 10.1 or later for proper operation of the 1260-64M in message-based mode.

Channel Descriptors For The 1260-64M

The standard 1260-01T commands are used to operate the 1260-64M module. These commands are described in the 1260-01T User's Manual.

Each 1260-01T relay command uses a *channel descriptor* to select the channel(s) of interest. The syntax for a channel descriptor is the same for all 1260 series modules. In general, the following syntax is used to select a single channel:

```
(@ <module address> ( <channel> ) )
```

Where:

- <module address> is the address of the 1260-64M module. This is a number in the range from 1 through 12, inclusive. Consult the “Setting the Module Address” paragraph in chapter 2 for a description of how to set the 1260-64M's module address.
- <channel> is the 1260-64M channel to operate. The valid channel numbers are determined by the type of plug-ins installed into the 1260-64M.

Multiple individual channels may be specified using the following channel descriptor syntax:

```
@ <module address> ( <chan1> , <chan2>  
, . . . , <chanN> )
```

A range of channels may be specified using the following channel descriptor syntax:

```
@ <module address> ( <first channel> :  
<last channel> )
```

The following examples illustrate the use of the channel descriptors for the 1260-64M:

```
OPEN (@8(0))      Open channel 0 on the 1260-64M  
                  that has module address 8.
```

```
CLOSE (@8(0,203)) Close channels 0 and 203 on the  
                  1260-64M that has module  
                  address 8.
```

```
CLOSE (@2(400:413)) Close channels 400 through 413  
                   inclusive on the 1260-64M that  
                   has module address 2.
```

Channel Values For The 1260-64M

The <channel> values that are valid for the 1260-64M are based on the type of plug-in modules installed. The 1260-64M provides 5 plug-in positions. The channel values used to close and open relays are based on both the plug-in position and the type of plug-in installed.

In general, the range of values accepted for a plug-in are shown below:

Position 1 => Channels 0 through 11

Position 2 => Channels 100 through 111

Position 3 => Channels 200 through 211

Position 4 => Channels 300 through 311

Position 5 => Channels 400 through 431

The absolute maximum values for channels in each position is shown. However, depending on the type of plug-in module installed, the channel value accepted for a position may be less than that which is shown above.

Position 5, when populated, will ALWAYS contain the 32-channel driver. Thus, the valid range of channels for this position will ALWAYS be 400 through 431 when the 32-channel driver is present.

If a position is not populated with a plug-in module, then there is no channel numbers accepted for the empty position.

For each of the positions 1 through 4, the maximum value accepted for the position is based on the type of plug-in module installed at the position:

Single 1x2 MUX	Channel X00 only
Double 1x2 MUX	Channel X00 and X01
Triple 1x2 MUX	Channel X00, X01, and X02
2x2 Transfer Switch	Channel X00 only
1x4 MUX	Channel X00 through X03
1x5 MUX	Channel X00 through X04
1x6 MUX	Channel X00 through X05
1x7 MUX	Channel X00 through X06
1x8 MUX	Channel X00 through X07
1x10 MUX	Channel X00 through X09
1x12 MUX	Channel X00 through X11

In the table above, the X is the leading digit (0 to 3) that corresponds to the position of the plug-in (1 to 4). Note that the leading digit is always 1 less than the position for the plug-in.

The least significant 2 digits of a <channel> indicate which relay is being operated. For the MUX plug-ins, the least significant 2 digits of the <channel> indicate which pole will be connected to the COM output.

For example, a 1x6 MUX installed in position 3 will be addressed using channels 200 through 205. By closing channel 200, the first pole is connected to the COM output. By closing channel 205, the last pole is connected to the COM output.

Each 1x2 MUX is selected by a single channel. When a 1x2 MUX is closed, the COM output is connected to the “Normally Open” (NO) input. When a 1x2 MUX is open, the COM output is connected to the “Normally Closed” (NC) input.

When a multi- 1x2 MUX plug-in is installed, the channels identify which of the MUXes are being selected. For triple 1x2 MUXes, channel X00 selects the first MUX on the plug-in, channel X01 selects the second MUX on the plug-in, and channel X02 selects the third MUX on the plug-in.

The 2x2 Transfer Switch may either be “opened” or “closed” as well. When the 2x2 Transfer Switch is “open”, the inputs are passed straight through to the outputs. When the switch is “closed”, the inputs are swapped to the alternate output. That is, input 1 is connected to output 2, and input 2 is connected to output 1.

Reply To The MOD:LIST? Command

The 1260-01T returns a reply to the MOD:LIST? command. This reply is unique for each different 1260 series switch module. The syntax for the reply is:

```
<module address> : <module-specific identification string>
```

The <module-specific identification string> for the 1260-64M is:

```
1260-64M UNIVERSAL VXI MICROWAVE RELAY CARRIER
```

So, for a 1260-64M whose <module address> is set to 8, the reply to this query would be:

```
8: 1260-64M UNIVERSAL VXI MICROWAVE RELAY  
CARRIER
```

Reply To The MOD:CONF? Command

The 1260-01T returns a reply to the “MOD:CONF?” command. This command is supported only in 1260-01T firmware at revision 10.1 or later. The reply to this command indicates the type of plug-ins that have been detected at each position within the 1260-64M.

The format for the “MOD:CONF?” command is:

```
MODule:CONFiguration? (@ <module address> )
```

For example, the command:

```
MOD:CONF? (@2)
```

queries the 1260-01T to determine which plug-ins are installed in the 1260-64M which has module address 2.

The reply to the “MOD:CONF?” command has the format:

```
1 : <PI1> ; 2 : <PI2> ; 3 : <PI3> ; 4 : <PI4> ;  
5 : <PI5>
```

where <PI1> through <PI5> will be replaced by text indicating the type of plug-in installed in the position. The text strings will be one of the following:

```
Empty  
Single 1x2 Non Latching MUX  
Double 1x2 Non Latching MUX  
Triple 1x2 Non Latching MUX  
2x2 Non Latching Transfer  
1x4 Non Latching MUX  
1x5 Non Latching MUX  
1x6 Non Latching MUX  
1x7 Non Latching MUX
```

```
1x8 Non Latching MUX
1x10 Non Latching MUX
1x12 Non Latching MUX
Single 1x2 Non Latching MUX
Double 1x2 Non Latching MUX
Triple 1x2 Non Latching MUX
2x2 Latching Transfer
1x4 Latching MUX
1x5 Latching MUX
1x6 Latching MUX
1x7 Latching MUX
1x8 Latching MUX
1x10 Latching MUX
1x12 Latching MUX
32 Channel Non Latching Port Driver
```

A sample reply is shown below:

```
1 : 1x4 Latching MUX ; 2 : Empty ; 3 : Empty ;
4 : Triple 1x2 Non Latching MUX ; 5 : 32
Channel Non Latching Port Driver
```

With this sample configuration, the valid channel numbers for the 1260-64M would be:

```
0 to 3      (1x4 MUX in position 1)
300 to 302  (3 1x2 MUXes in position 4)
400 to 431  32 channel driver in position 5
```

Latching versus Non Latching Operation

In the list of possible replies from the “MOD:CONF?” query, you can see that the description of a plug-in module contains an indication of whether the plug-in is “Latching” or “Non Latching”.

The manner in which the 1260-01T controls latching plug-ins differs from that used to control non-latching plug-ins in four ways:

- 1) When the VXI chassis is powered off, the latching relays remain in the last position that was commanded. Non latching relays will return to the default state
- 2) When the VXI chassis is powered on, the present state of the latching relays is read back and recorded. Non-latching relays will be set by the 1260-01T to an “all open” state
- 3) Latching relays are operated by pulsing a control signal on and then off. Non latching relays are operated by keeping the control signal in the asserted state.
- 4) When a latching 1xN MUX is commanded to open all N channels of the MUX, the firmware will ensure that the first channel in the MUX is connected to the COM output of the MUX. The latching MUX cannot be set to a “no connection”

position. The COM output of the MUX will always be connected to one of the inputs.

Operating in Register-Based Mode

In register-based mode, the 1260-64M is operated by directly writing and reading control registers on the 1260-64M module. For the channel assignments for each control register, see Table 3-1.. When a control register is written to, all channels controlled by that register are operated simultaneously.

The control registers are located in the VXIbus A24 Address Space. The A24 address for a control register depends on:

1. The A24 Address Offset assigned to the 1260-01T module by the Resource Manager program. The Resource Manager program is provided by the VXIbus slot-0 controller vendor. The A24 Address Offset is placed into the "Offset Register" of the 1260-01T by the Resource Manager.
2. The <module address> of the 1260-64M module. This is a value in the range from 1 and 12 inclusive.
3. The 1260-64M control register to be written to or read from. Each control register on the 1260-64M has a unique address.

The base A24 address for the 1260-64M module may be calculated by:

$$(A24 \text{ Offset of the } 1260-01T) + (1024 \times \text{Module Address of } 1260-64M).$$

The A24 address offset is usually expressed in hexadecimal. A typical value of 204000_{16} is used in the examples that follow.

A 1260-64M with a module address of 7 would have the base A24 address computed as follows:

$$\begin{aligned} \text{Base A24 Address of } 1260-64M &= 204000_{16} + (400_{16} \times 7_{10}) \\ &= 205C00_{16} \end{aligned}$$

The control registers for Adapt-a-Switch plug-ins and conventional 1260-Series modules are always on odd-numbered A24 addresses. The three control registers for the 1260-64M reside at the first three odd-numbered A24 addresses for the module:

$$(\text{Base A24 Address of } 1260-64M) + 1 = \text{Control Register 0}$$

$$(\text{Base A24 Address of } 1260-64M) + 3 = \text{Control Register 1}$$

(Base A24 Address of 1260-64M) + 5 = Control Register 2

So, for our example, the first three control registers are located at:

205C01 Control Register 0
 205C03 Control Register 1
 205C05 Control Register 2

Table 3-1 shows the control registers used by the 1260-64M.

Table 3-1, Control Register Memory Map

Control Register	Offset from Base A24 Address (Hex)	Comments
0	1	Data write / read back for the 1 st 8-bits of plug-in #1
1	3	Data write / read back for the 2 nd 8-bits of plug-in #1
2	5	Data write / read back for the 1 st 8-bits of plug-in #2
3	7	Data write / read back for the 2 nd 8-bits of plug-in #2
4	9	Data write / read back for the 1 st 8-bits of plug-in #3
5	B	Data write / read back for the 2 nd 8-bits of plug-in #3
6	D	Data write / read back for the 1 st 8-bits of plug-in #4
7	F	Data write / read back for the 2 nd 8-bits of plug-in #4
8	11	Data write / read back for the 1 st 8-bits of 32-bit driver (LSB)
9	13	Data write / read back for the 2 nd 8-bits of 32-bit driver
10	15	Data write / read back for the 3 rd 8-bits of 32-bit driver
11	17	Data write / read back for the 4th 8-bits of 32-bit driver (MSB)
12	19	Configuration ID read back for plug-in slot #1
13	1B	Configuration ID read back for plug-in slot #2
14	1D	Configuration ID read back for plug-in slot #3
15	1F	Configuration ID read back for plug-in slot #4
16	21	Configuration ID read back for plug-in slot #5
<break>	<break>	<break>
	201	ID byte read back for module
	203	read location for on-board configuration PROM

Plug-In Module ID Codes

Within the control register map displayed in Table 3-1, the configuration ID information may be read back from control registers 12 through 16. These correspond to offset addresses 19 through 21 (hexadecimal).

Each different type of plug-in module has a unique 5-bit code associated with it. By reading the configuration registers 12 through 16, the software may determine what type of plug-in modules have been installed in the 1260-64M.

The plug-in identification codes are shown in Table 3-2 below.

Table 3-2, Plug-In Module ID Codes

ID Value (hex)	Plug-In Module Type
00	Empty
01	2x2 Transfer Non-Latching
02	Single 1x2 Non Latching MUX
03	Triple 1x2 Non Latching MUXes
04	1x4 Non Latching MUX
05	1x5 Non Latching MUX
06	1x6 Non Latching MUX
07	1x7 Non Latching MUX
08	1x8 Non Latching MUX
09	32 Channel Driver (Non Latching)
0A	1x10 Non Latching MUX
0B	<not used – reserved>
0C	1x12 Non Latching MUX
0D	<not used – reserved>
0E	<not used – reserved>
0F	<not used – reserved>
10	Double 1x2 Latching MUXes
11	2x2 Latching Transfer
12	Single 1x2 Latching MUX
13	Triple 1x2 Latching MUXes
14	1x4 Latching MUX
15	1x5 Latching MUX
16	1x6 Latching MUX
17	1x7 Latching MUX
18	1x8 Latching MUX
19	<not used – reserved>
1A	1x10 Latching MUX
1B	<not used – reserved>
1C	1x12 Latching MUX
1D	<not used – reserved>
1E	<not used – reserved>
1F	Double 1x2 Non Latching MUXes

Operating the Plug-In Modules

Each plug-in module is controlled by writing to the control registers associated with the plug-in.

The 32-Channel driver is controlled by four 8-bit control registers.

This plug-in is always operated via control registers 8, 9, 10, and 11 as shown in Table 3-1.

The 1x10 and 1x12 MUXes are each controlled by two 8-bit control registers.

The remainder of the plug-in modules controlled by a single 8-bit control register. These plug-in modules are controlled using the lower 8-bit control port shown in Table 3-1. The upper 8-bit port for these plug-ins have no effect.

Table 3-1 displays the memory map used to control the plug-in modules. Note that each plug-in has its own 1- or 2-byte control register based on the position in which the plug-in resides.

Operating the Latching 1x2 MUXes

There are three different plug-in modules which provide 1, 2, or 3 1x2 latching MUXes.

The single 1x2 latching MUX is controlled by writing to the least significant 2 bits of the control register (bits 0 and 1)

The double 1x2 latching MUX is controlled by writing to the least significant 2 bits of the control register for MUX #1. MUX #2 is controlled by the next two adjacent bits (bits 2 and 3)

The triple 1x2 latching MUX is controlled by writing the least significant 2 bits of the control register for MUX #1. MUX #2 is controlled by the next two adjacent bits (bits 2 and 3). MUX #3 is controlled by bits 4 and 5.

The control bit assignments for the 1x2 latching MUX plug-in modules is shown below.

Bit 7 (MSB)	Bit 6	Bit 5	Bit 4	Bit 3	Bit 2	Bit 1	Bit 0 (LSB)
--	--	Close MUX 3	Open MUX 3	Close MUX 2	Open MUX 2	Close MUX 1	Open MUX 1

The Latching MUXes are controlled by pulsing the control bit (or bits) to achieve the desired operation. Pulsing is achieved by:

- Write a '1' to the control register bit (or bits)
- Wait 20 to 100 milliseconds
- Write a 0 to the control register (all bits off)

The 1x2 MUX can be opened by pulsing a 1 to the "Open MUX" bit for the desired MUX. When the 1x2 MUX is "open", the COM output is connected to the "Normally Closed" (NC) input

The 1x2 MUX can be closed by pulsing a 1 to “Close MUX” bit for the desired MUX. When the 1x2 MUX is “closed”, the COM output is connected to the “Normally Open” (NO) input.

The present state of the latching 1x2 MUX can be read back by reading the control register as follows:

- 1) Read the control register for the 1x2 MUX(es)
- 2) Invert the bits (swap 0's and 1's – a “one's complement”)
- 3) If the “OPEN MUX” bit for the MUX = 1, the MUX is open
- 4) If the “CLOSE MUX” bit for the MUX = 1, the MUX is closed

For example, suppose a triple 1x2 latching MUX is installed in position #3. To read-back the status of each of the MUXes, you would read control register #4 as shown in Table 3-1. Suppose that the data read back from control register #4 = 1110 0101 (binary) = E5 (hex). After inverting the bits (one's complement) the data = 0001 1010 (binary) = 1A (hex). This indicates that MUX 1 and MUX 2 are closed while MUX 3 is open.

Operating the Latching 2x2 Transfer Switch

The Latching 2x2 Transfer Switch is controlled in the same manner as the single Latching 1x2 MUX. Pulsing the least significant bit (bit 0) of the control register will “open” the transfer switch. Pulsing the adjacent (bit 1) of the control register will “close” the transfer switch.

When the transfer switch is “open”, the outputs are connected to the corresponding inputs. That is, input 1 is connected to output 1 and input 2 is connected to output 2. When the transfer switch is “closed”, the outputs are swapped, so that input 1 is connected to output 2 and input 2 is connected to output 1.

The present state of the 2x2 Latching Transfer Switch may be read back by following the same procedure as the one described for the single 1x2 Latching MUX.

Operating the Latching 1x4, 1x5, 1x6, 1x7, and 1x8 MUXes

Each of the 1x4, 1x5, 1x6, 1x7, and 1x8 latching MUXes are controlled by a single control register. The control register assigned to the plug-in is based on the position within the 1260-64M as shown in Table 3-1.

Each pole of the MUX is connected to the COM output by pulsing the control bit high and then low. The duration of the pulse must be between 20 and 100 milliseconds.

The control bit assignments for the 1xN latching MUX plug-in modules is shown below:

Bit 7 (MSB)	Bit 6	Bit 5	Bit 4	Bit 3	Bit 2	Bit 1	Bit 0 (LSB)
Pole 8	Pole 7	Pole 6	Pole 5	Pole 4	Pole 3	Pole 2	Pole 1

Naturally, if the 1xN MUX has less than 8 poles, the additional control bits are not used and can be ignored.

Thus, to connect pole 5 to COM on a 1x6 latching MUX installed in plug in position #4, you would:

- 1) Write the value 0001 0000 (binary = 10 hex) to control register 6
- 2) Delay 20 to 100 milliseconds
- 3) Write the value 0 to control register

The present state of the 1xN MUX can be determined by reading the control register as described below:

- 1) Read the control register for the 1xN MUX
- 2) Invert the bits (swap 0's and 1's – a “one's complement”)
- 3) Only one of the bits should be high (1). The pole that is associated with that bit is the pole that is connected to the COM output of the MUX

Note that in step 3, you should mask off the unused bits of the control register when looking for the high bit. That is, if the plug-in module is a 1x6 MUX, you should mask off bits 6 and 7 since these bits have no meaning for a 1x6 MUX.

Operating the Latching 1x10 and 1x12 MUXes

The 1x10 and 1x12 latching MUXes are controlled using 2 adjacent control registers. The control registers assigned to the plug-in are based on the position within the 1260-64M as shown in Table 3-1.

Each pole of the MUX is connected to the COM output by pulsing the control bit high and then low. The duration of the pulse must be between 20 and 100 milliseconds.

The control bit assignments for the 1x10 and 1x12 latching MUX plug-in modules is shown below. Note that poles 11 and 12 do NOT exist for the 1x10 MUX and so these can be ignored for the 1x10 plug-in module.

Control Register N

Bit 7 (MSB)	Bit 6	Bit 5	Bit 4	Bit 3	Bit 2	Bit 1	Bit 0 (LSB)
Pole 8	Pole 7	Pole 6	Pole 5	Pole 4	Pole 3	Pole 2	Pole 1

Control Register N+1

Bit 7 (MSB)	Bit 6	Bit 5	Bit 4	Bit 3	Bit 2	Bit 1	Bit 0 (LSB)
---		---	---	Pole 12	Pole 11	Pole 10	Pole 9

The control register used (N) depends on the position of the plug-in as shown in Table 3-1:

- Position 1 N = 0
- Position 2 N = 2
- Position 3 N = 4
- Position 4 N = 6

Note that since only one of the poles may be connected to the COM output, only one of the two control registers need to be written to create the desired connection. For example, if you want to connect pole 9 to the COM output, you must write to Control Register N+1, but you do not need to write to Control Register N.

Reading back the state of the 1x10 and 1x12 MUXes requires that both control registers be read:

- 1) Read control register N
- 2) Invert the bits (swap 0's and 1's)
- 3) If a bit is set (data value is not 0), then the MUX is connected to pole X+1, where bit X = 1.
- 4) If no bit is set, then read control register N+1
- 5) Invert the bits (swap 0's and 1's)
- 6) Mask off the unused bits (AND with 0F [hex] for 1x12 or 03 for 1x10)
- 7) Find the bit that is set. If bit X is set, then pole X+9 is connected to the COM output.

Operating the Non-Latching 1x2 MUXes

There are three different plug-in modules which provide 1, 2, or 3 1x2 Non-latching MUXes.

Each 1x2 MUX is controlled by a single control bit in the control register. If the bit is set high (1), the corresponding 1x2 MUX will be closed. If the bit is set low (0), the corresponding 1x2 MUX will be opened.

When a 1x2 MUX is closed, the COM output is connected to the Normally Open (NO) input. When the 1x2 MUX is open, the COM output is connected to the Normally Closed (NC) input.

The control bit assignments for the 1x2 non-latching MUX plug-in modules is shown below.

Bit 7 (MSB)	Bit 6	Bit 5	Bit 4	Bit 3	Bit 2	Bit 1	Bit 0 (LSB)
--	--	--	--	--	MUX 3	MUX 2	MUX 1

Unlike the latching 1x2 MUXes, the control bit for each MUX must remain high (1) as long as the MUX is to be closed. If the control bit is set low (0), or if the power is removed from the module, the MUX will open.

The present state of the relay coils for the MUXes may be read back from the control register. The data should be inverted (one's complement) when it is read back. The (inverted) data read back from the control register should equal the value written to the control register.

Operating the Non-Latching 2x2 Transfer Switch

The Non-Latching 2x2 Transfer Switch is controlled in the same manner as the single Non-Latching 1x2 MUX. Clearing the least significant bit (bit 0) of the control register will "open" the transfer switch. Setting the least significant bit (bit 0) of the control register will "close" the transfer switch.

When the transfer switch is "open", the outputs are connected to the corresponding inputs. That is, input 1 is connected to output 1 and input 2 is connected to output 2. When the transfer switch is "closed", the outputs are swapped, so that input 1 is connected to output 2 and input 2 is connected to output 1.

The present state of the relay coil for the 2x2 transfer switch may be read back from the control register. The data should be inverted (one's complement) after it is read back. The (inverted)

value read for bit 0 should be equal to the value of bit 0 that was written to the control register.

Operating the Non-Latching 1x4, 1x5, 1x6, 1x7, and 1x8 MUXes

Each of the 1x4, 1x5, 1x6, 1x7, and 1x8 non-latching MUXes are controlled by a single control register. The control register assigned to the plug-in is based on the position within the 1260-64M as shown in Table 3-1.

The control bit assignments for the 1xN non-latching MUX plug-in modules is shown below:

Bit 7 (MSB)	Bit 6	Bit 5	Bit 4	Bit 3	Bit 2	Bit 1	Bit 0 (LSB)
Pole 8	Pole 7	Pole 6	Pole 5	Pole 4	Pole 3	Pole 2	Pole 1

Naturally, if the 1xN MUX has less than 8 poles, the additional control bits are not used and can be ignored.

A single pole may be connected to the COM output of the by setting the corresponding bit within the control register. The control bit must remain high (1) for the pole to continue to be connected to the COM output.

There should be at most 1 of the 8 control register bits set to a 1 at any one time. You should never set two or more bits of the control register high at the same time.

The present state of the relay coils for the 1xN MUX may be read back from the control register. The value read back from the control register must be inverted (one's complement). The (inverted) value read back from the control register should equal the value written to the control register.

Operating the Non-Latching 1x10 and 1x12 MUXes

The Non-latching 1x10 and 1x12 MUXes are controlled using 2 adjacent control registers. The control registers assigned to the plug-in are based on the position within the 1260-64M as shown in Table 3-1.

A single pole may be connected to the COM output of the MUX by setting the control bit associated with the pole.

The control bit assignments for the 1x10 and 1x12 latching MUX plug-in modules is shown below. Note that poles 11 and 12 do NOT exist for the 1x10 MUX and so these can be ignored for the

1x10 plug-in module.

Control Register N

Bit 7 (MSB)	Bit 6	Bit 5	Bit 4	Bit 3	Bit 2	Bit 1	Bit 0 (LSB)
Pole 8	Pole 7	Pole 6	Pole 5	Pole 4	Pole 3	Pole 2	Pole 1

Control Register N+1

Bit 7 (MSB)	Bit 6	Bit 5	Bit 4	Bit 3	Bit 2	Bit 1	Bit 0 (LSB)
---		---	---	Pole 12	Pole 11	Pole 10	Pole 9

The control register used (N) depends on the position of the plug-in as shown in Table 3-1:

- Position 1 N = 0
- Position 2 N = 2
- Position 3 N = 4
- Position 4 N = 6

One control register should be set to 0, while the other control register should have at most 1 bit set high (1) at any one time. Only 1 pole may be connected to the COM output at any one time.

The present state of the relay coils for the 1xN MUX may be read back from the control register. The values read back from the control registers must be inverted (one's complement). The (inverted) value read back from each control register should equal the value written to that control register.

Operating the Non-Latching 32-Channel Driver

The Non-latching 32-channel driver provides independent control of 32 channel drivers. The 32-channel driver, when installed, will always be located in position #5.

The control register assignment for the 32-channel driver is shown below:

Control Register 8

Bit 7 (MSB)	Bit 6	Bit 5	Bit 4	Bit 3	Bit 2	Bit 1	Bit 0 (LSB)
Chan 407	Chan 406	Chan 405	Chan 404	Chan 403	Chan 402	Chan 401	Chan 400

Control Register 9

Bit 7 (MSB)	Bit 6	Bit 5	Bit 4	Bit 3	Bit 2	Bit 1	Bit 0 (LSB)
Chan 415	Chan 414	Chan 413	Chan 412	Chan 411	Chan 410	Chan 409	Chan 408

Control Register 10

Bit 7 (MSB)	Bit 6	Bit 5	Bit 4	Bit 3	Bit 2	Bit 1	Bit 0 (LSB)
Chan 423	Chan 422	Chan 421	Chan 420	Chan 419	Chan 418	Chan 417	Chan 416

Control Register 11

Bit 7 (MSB)	Bit 6	Bit 5	Bit 4	Bit 3	Bit 2	Bit 1	Bit 0 (LSB)
Chan 431	Chan 430	Chan 429	Chan 428	Chan 427	Chan 426	Chan 425	Chan 424

The control registers each control 8 channels. The channels shown above indicate the channel designators used when the message-based interface is used.

Each channel is closed by writing a 1 to the corresponding control bit. Each channel is opened by writing a 0 to the corresponding control bit.

The present value for each of these control registers may be read back from the control register. The value read back from the control registers must be inverted (one's complement). The (inverted) value read from the control register should be equal to the value written to the control register.

1260-64M Example Code

```
#include <visa.h>

/*
 * Example assumes that the 1260-64M has the following plug-in modules:
 *
 *   Position 1:   1x4 Latching MUX
 *   Position 2:   Double 1x2 Latching MUX
 *   Position 3:   1x6 Non-Latching MUX
 *   Position 4:   2x2 Non-Latching Transfer Switch
 *   Position 5:   32-channel driver
 */

/* This example shows a 1260-01T at logical address 16 and a VXI/MXI */
/* interface */
#define RI1260_01_DESC      "VXI::16"

/* For a GPIB-VXI interface, and a logical address of 77 */
/* the descriptor would be: "GPIB-VXI::77" */

/* this example shows a 1260-64M with module address 7 */
#define MOD_ADDR_64M      7

ViStatus example_operate_1260_64M(void)
{
    ViUInt8 read_data;
    ViUInt8 write_data;
    ViBusAddress addr_plugin_1;
    ViBusAddress addr_plugin_2;
    ViBusAddress addr_plugin_3;
    ViBusAddress addr_plugin_4;
    ViBusAddress addr_plugin_5;
    ViSession hdl1260;      /* VISA handle to the 1260-01T */
    ViSession hdlRM;        /* VISA handle to the resource manager */
    ViStatus error;         /* VISA error code */
    ViStatus error2;       /* second VISA error code */

    /* open the resource manager */
    /* this must be done once in application program */
    error = viOpenDefaultRM (&hdlRM);

    if (error < 0) {
        /* error handling code goes here */
    }
}
```

```
}

/* get a handle for the 1260-01T */
error = viOpen (hdlRM, RI1260_01_DESC, VI_NULL,VI_NULL, &hdl1260);
if (error < 0) {
    /* error handling code goes here */
}

/* form the offset for base addresses of the plug-in modules */
/* note that the base A24 Address for the 1260-01T */
/* is already accounted for by VISA calls viIn8() and */
/* viOut8() */

/* module address shifted 10 places = module address x 1024 */
addr_plugin_1 = (MOD_ADDR_64M << 10) + 1;
addr_plugin_2 = addr_plugin_1 + 4;
addr_plugin_3 = addr_plugin_2 + 4;
addr_plugin_4 = addr_plugin_3 + 4;
addr_plugin_5 = addr_plugin_4 + 4;

/* connect pole 4 to COM output of 1x4 latching MUX in position 1 */
write_val = 0x08;
error = viOut8 (hdl1260, VI_A24_SPACE, addr_plugin_1, write_val);

/* wait 50 milliseconds before turning off latching pulse */
Delay( 0.05 );

/* turn off latching pulse */
write_val = 0x00;
error2 = viOut8 (hdl1260, VI_A24_SPACE, addr_plugin_1, write_val);

/* check errors from VISA operations */
if (error < 0)
    return( error );

if (error2 < 0)
    return( error2 );

/* close double 1x2 MUX #1 */
/* assert the CLOSE MUX control bit */
write_val = 0x02;
error = viOut8 (hdl1260, VI_A24_SPACE, addr_plugin_2, write_val);

/* wait 50 milliseconds before turning off latching pulse */
Delay( 0.05 );

/* turn off latching pulse */
```



```
write_val = 0x00;
error2 = viOut8 (hdl1260, VI_A24_SPACE, addr_plugin_2, write_val);

/* check errors from VISA operations */
if (error < 0)
    return( error );

if (error2 < 0)
    return( error2 );

/* now OPEN double 1x2 MUX #1 */
/* assert the OPEN MUX control bit */
write_val = 0x01;
error = viOut8 (hdl1260, VI_A24_SPACE, addr_plugin_2, write_val);

/* wait 50 milliseconds before turning off latching pulse */
Delay( 0.05 );

/* turn off latching pulse */
write_val = 0x00;
error2 = viOut8 (hdl1260, VI_A24_SPACE, addr_plugin_2, write_val);

/* check errors from VISA operations */
if (error < 0)
    return( error );

if (error2 < 0)
    return( error2 );

/* select pole 5 of the 1x6 Non-Latching MUX */
write_val = 0x10;
error = viOut8 (hdl1260, VI_A24_SPACE, addr_plugin_3, write_val);

/* check errors from VISA operations */
if (error < 0)
    return( error );

/* now set the channel relay driver for channel 400 with out */
/* affecting the other relay driver states */
error = viIn8 (hdl1260, VI_A24_SPACE, addr_plugin_4, &read_val);
if (error < 0) {
    /* error handling code goes here */
}

/* invert the value read back */
write_val = ~ read_val;
```

```
/* AND to leave every channel except channel 400 unchanged */
write_val &= ~ (0x01);

/* OR in the bit to close channel 400 */
write_val |= 01;

/* write the updated control register value */
error = viOut8 (hdl1260, VI_A24_SPACE, addr_plugin_4, write_val);
if (error < 0) {
    /* error handling code goes here */
}

/* open channel 431 without affecting channels 424 to 430 */
error = viIn8 (hdl1260, VI_A24_SPACE, (addr_plugin_4 + 6),
              &read_val);
if (error < 0) {
    /* error handling code goes here */
}

/* invert the bits to get the present control register value */
write_val = ~read_val;

/* AND to leave every channel except 93 unchanged */
/* leave bit 0 clear to open channel 93 */
write_val &= ~ (0x80);

/* write the updated control register value */
error = viOut8 (hdl1260, VI_A24_SPACE, (addr_plugin_4 + 6),
              write_val);
if (error < 0) {
    /* error handling code goes here */
}

/* close the VISA session */
error = viClose( hdl1260 );
if (error < 0) {
    /* error handling code goes here */
}

/* close the resource manager session */
error = viClose( hdlRM );
return( error );
}
```

Chapter 4

CONNECTOR PIN CONFIGURATION

RF Relays

Figure 4-1 shows the location of four plug-ins on the front panel of the 1260-64M module. The actual configuration is application dependent.

Relay Banks

Figure 4-2 shows the pin locations for the 50-pin Relay Bank connector, J1. Table 4-1 lists the J1 pin signals. Connector J1 is Racal Instruments Part Number 601856-050. The mating connectors are Racal Instruments Part Number 601855-050 for the connector body, and 601857 for the pins.

Each of the two relay banks can be independently configured as a sink or a source driver. Either the VXI mainframe or an external supply can be selected.

WARNING

The user must use caution when wiring to the module to prevent damage to the relay banks.

The 1260-64M contains some internal protection circuitry. The internal current sourcing and handling capabilities of the module and the mainframe must not be exceeded. Properly interface external loads, especially if they are inductive. If an external supply is used, the external B+ and B- lines **MUST** be connected to the External B+ and the External Ground pins on J1. Flyback-clamping suppression diodes **MUST** be connected across any inductive loads. (Switching of AC inductive loads is not recommended.) Figures 4-3 through 4-6 show correct methods interfacing to the 1260-64M relay banks.

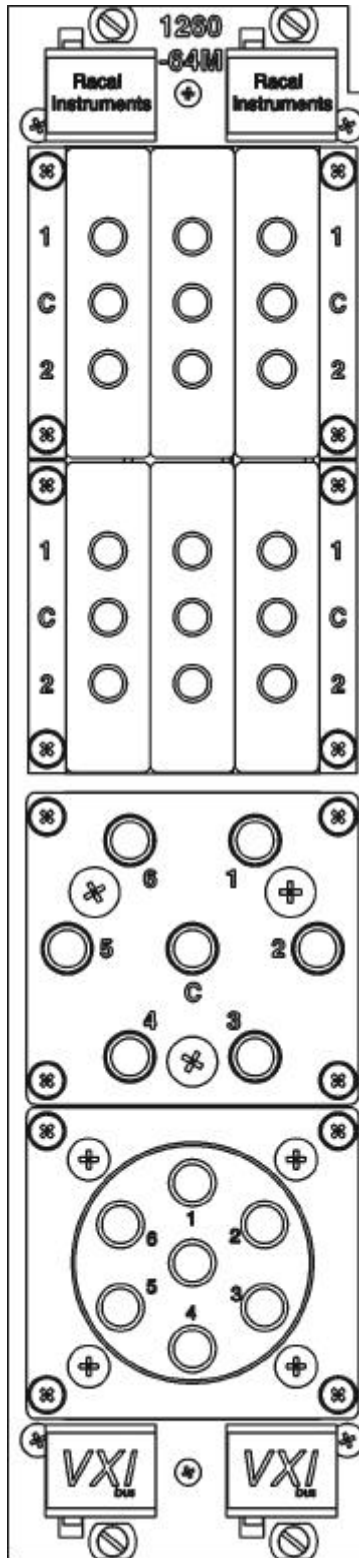

Figure 4-1, 1260-64M Front Panel

Table 4-1, 1260-64M Pin Assignments

BankA Pin	Function	BankB Pin	Function
A,C,E,H	External B+	B,D,F,J	External B+
X, y, z, AA	External Ground	CC,DD,EE	External Ground
z, AA, BB	External Ground	FF,HH	External Ground
d	Contact 0	p	Contact 0
L	Contact 1	V	Contact 1
b	Contact 2	T	Contact 2
S	Contact 3	M	Contact 3
a	Contact 4	W	Contact 4
k	Contact 5	e	Contact 5
t	Contact 6	r	Contact 6
w	Contact 7	m	Contact 7
j	Contact 8	u	Contact 8
R	Contact 9	z	Contact 9
x	Contact 10	N	Contact 10
P	Contact 11	K	Contact 11
Y	Contact 12	U	Contact 12
h	Contact 13	c	Contact 13
v	Contact 14	n	Contact 14
s	Contact 15	f	Contact 15

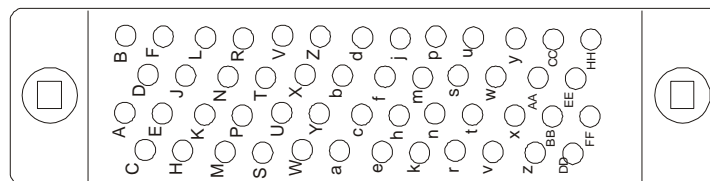

Figure 4-2, Relay Bank Pin Configuration (J1)

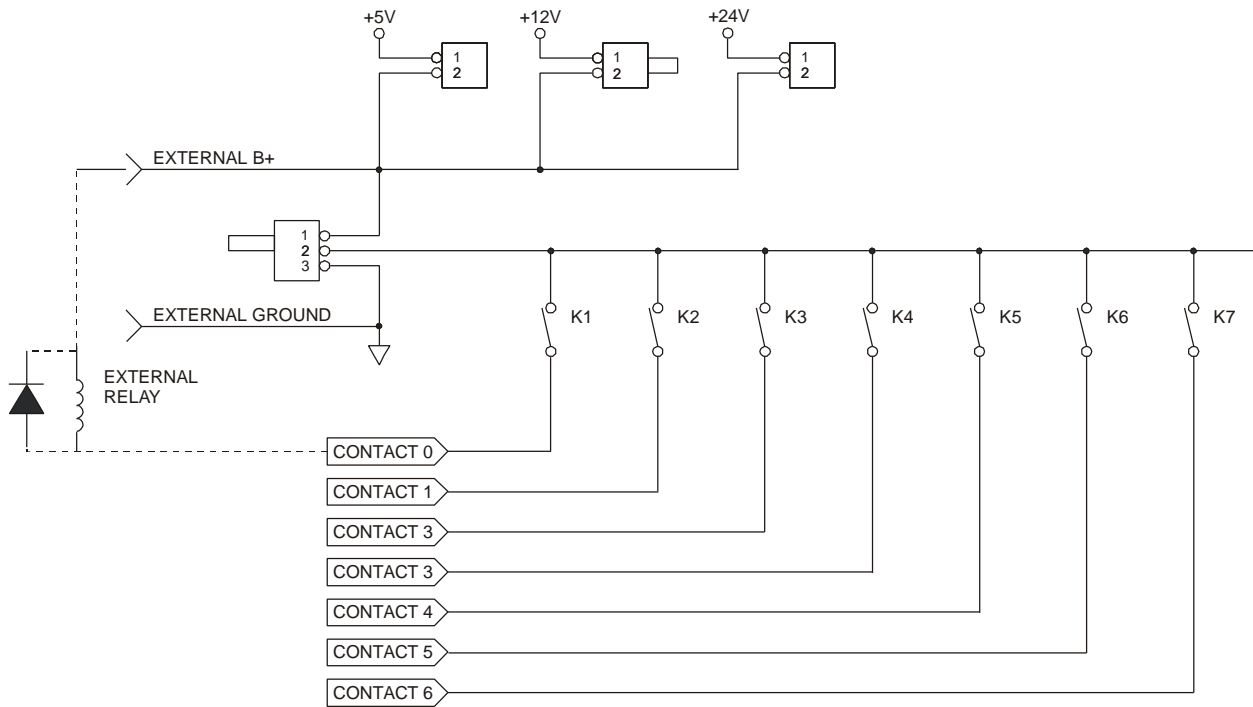

Figure 4-3, Internal Supply Sink Driver Example

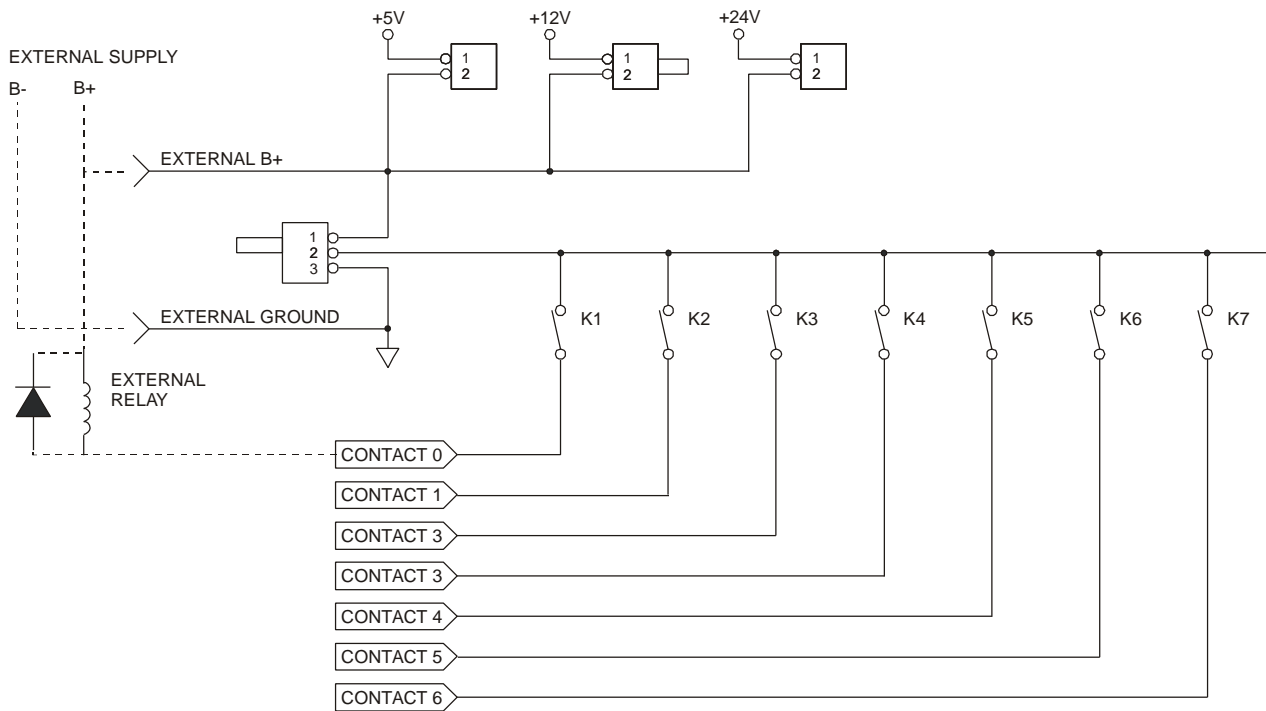

Figure 4-4, External Supply Sink Driver Example

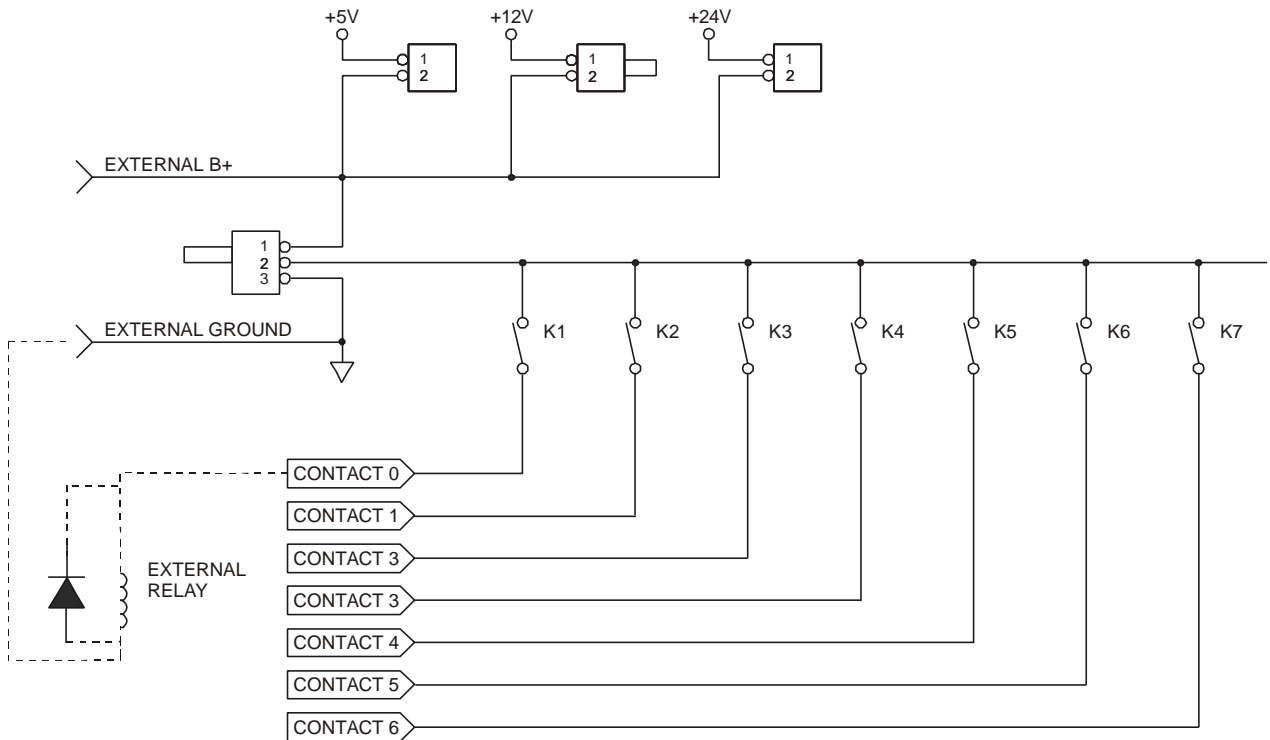

Figure 4-5, Internal Supply Source Driver Example

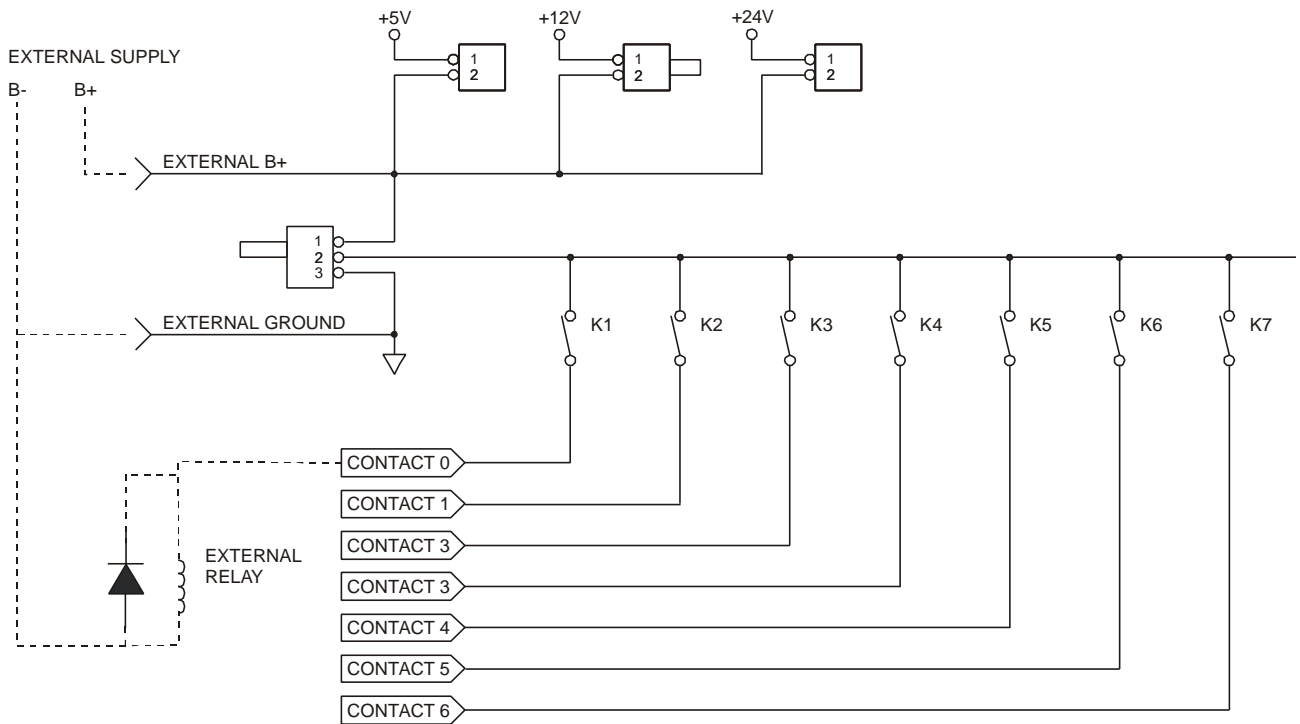

Figure 4-6, External Supply Source Driver Example

This page was left intentionally blank.

Chapter 5

THEORY OF OPERATION

PCB Assemblies

The 1260-64M consists of two PCB assemblies. A small PCB assembly is required to pass the local bus signals, LBUS 0 through LBUS 11, through the unused second slot of this double-wide module. The VXI IACK and BUS GRANT 0 through 3 signals are jumpered to allow the PCB assembly to be used in autoconfiguring backplanes.

The main logic PCB assembly contains DC relay banks, 1260 Local Bus interface circuitry, and drivers for both the relay bank and the RF relays. The VXI interface is described in the Theory of Operation section of the 1260 Series VXI Switching Cards Manual. The relay driver circuitry is contained in monolithic IC driver chips. The relay banks are shown in Figures 4-3 through 4-6. Not shown in these figures are internal clamp diodes. These diodes will clamp minor inductance effects, such as those caused by wiring; but they are not intended to replace suppression diodes across the solenoid coils of external relays, or other inductive loads. Referring to the schematic diagram, the diodes between the Contact lines and ground clamp switch-to-open transients when the bank is used as a source driver. The diodes between the Contact lines and the External B+ clamp switch-to-open transients when the bank is used as a sink driver.

This page was left intentionally blank.

Chapter 6

PRODUCT SUPPORT

Product Support

Racal Instruments has a complete Service and Parts Department. If you need technical assistance or should it be necessary to return your product for repair or calibration, call 1-800-722-3262. If parts are required to repair the product at your facility, call 1-949-859-8999 and ask for the Parts Department.

When sending your instrument in for repair, complete the form in the back of this manual.

For worldwide support and the office closes to your facility, refer to the Support Offices section on the following page.

Reshipment Instructions

Use the original packing material when returning the 1260-64M to Racal Instruments for calibration or servicing. The original shipping crate and associated packaging material will provide the necessary protection for safe reshipment.

If the original packing material is unavailable, contact Racal Instruments Customer Service for information.

Support Offices

Racal Instruments, Inc.

4 Goodyear St., Irvine, CA 92618-2002
Tel: (800) RACAL-ATE, (800) 722-2528,
(949) 859-8999; FAX: (949) 859-7139

Racal Instruments, Ltd.

480 Bath Road, Slough, Berkshire, SL1 6BE, United Kingdom
Tel: +44 (0) 1628 604455; FAX: +44 (0) 1628 662017

Racal Systems Electronique S.A.

18 Avenue Dutartre, 78150 LeChesnay, France
Tel: +33 (1) 3923 2222; FAX: +33 (1) 3923 2225

Racal Systems Elettronica s.r.l.

Strada 2-Palazzo C4, 20090 Milanofiori Assago, Milan, Italy
Tel: +39 (0)2 5750 1796; FAX +39 (0)2 5750 1828

Racal Elektronik System GmbH.

Technologiepark Bergisch Gladbach, Friedrich-Ebert-Strasse,
D-51429 Bergisch Gladbach, Germany
Tel.: +49 2204 8442 00; FAX: +49 2204 8442 19

Racal Instruments, Ltd.

Unit 5, 25F., Mega Trade Center, No 1, Mei Wan Road, Tsuen
Wan, Hong Kong, PRC
Tel: +852 2405 5500, FAX: +852 2416 4335

REPAIR AND CALIBRATION REQUEST FORM

To allow us to better understand your repair requests, we suggest you use the following outline when calling and include a copy with your instrument to be sent to the Racal Repair Facility.

Model _____ Serial No. _____ Date _____

Company Name _____ Purchase Order # _____

Billing Address _____

City _____

State/Province _____

Zip/Postal Code _____

Country _____

Shipping Address _____

City _____

State/Province _____

Zip/Postal Code _____

Country _____

Technical Contact _____ Phone Number () _____

Purchasing Contact _____ Phone Number () _____

1. Describe, in detail, the problem and symptoms you are having. Please include all set up details, such as input/output levels, frequencies, waveform details, etc. _____

2. If problem is occurring when unit is in remote, please list the program strings used and the controller type. _____

3. Please give any additional information you feel would be beneficial in facilitating a faster repair time (i.e., modifications, etc.) _____

4. Is calibration data required? Yes No (please circle one)

Call before shipping

Ship instruments to nearest support office

Note: We do not accept "collect" shipments.

listed on back.